

Modular. Robust. Reliable.

KLM Linear Module

With pneumatic drive and ball bushing guide.

Field of Application

For use in clean and slightly polluted environments. Simple economic linear movements or, in combination, as multi-axis positioning systems for assembly and handling technology.



Advantages – Your benefits

Double bearing of the guide shafts in the ball bushing for high load bearing capacity and repeat accuracy < 0.015 mm

Shock absorbers and proximity switches integrated in the projecting surfaces for vibration-free movements and end position monitoring

Strongly dimensioned guide shafts for high rigidity

High basic load ratings in all load directions

Standardized mounting bores for numerous combinations with other components from the modular system

Several intermediate positions possible for maximum flexibility in applications

Rod lock by means of clamping cartridge for safety in case of emergency stops

 <p>Sizes Quantity: 4</p>	 <p>Weight 0.5 .. 13.2 kg</p>	 <p>Driving force 67 .. 753 N</p>	 <p>Stroke 13 .. 300 mm</p>	 <p>Repeat accuracy 0.02 .. 0.03 mm</p>
--	--	--	--	--

Functional Description

The linear module is driven via a double-acting pneumatic cylinder which is integrated in the base body, and guided by two opposing guide rods.

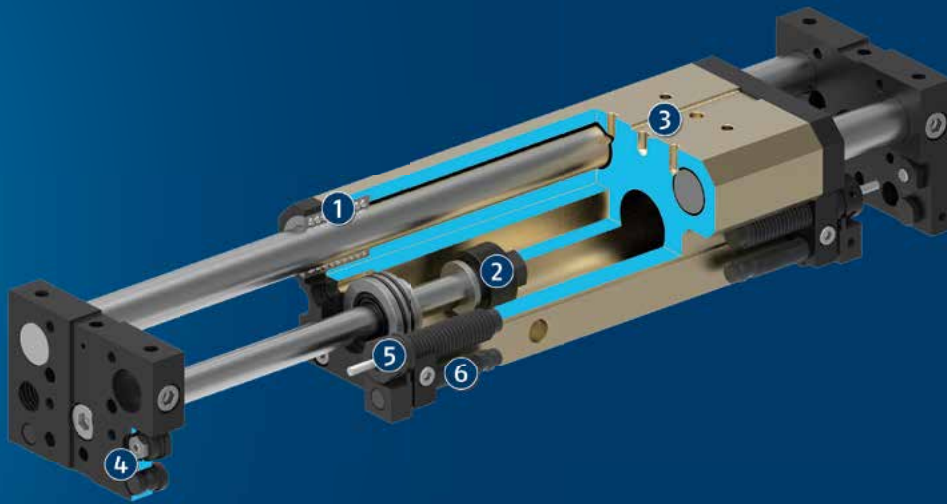

- ① **Ball bushing guide**
Scope-free at a low friction
- ② **Drive**
Powerful piston rod cylinders
- ③ **Mounting pattern**
Completely integrated in the module system
- ④ **Damping adjustment**
Adjustment of the damping characteristics
- ⑤ **End position adjustability**
Convenient adjustment using the shock absorber threads
- ⑥ **Sensor system**
with sensor driver for convenient adjustment

CAD data, operating manuals and other current product documents are available at [schunk.com](https://www.schunk.com)

General Notes on the Series

Housing material: Aluminum alloy, anodized

Guidance: Ball bushing guide

Actuation: pneumatic, with filtered compressed air as per ISO 8573-1:2010 [7:4:4].

Scope of delivery: Shock absorber and driver for proximity switch

Warranty: 24 months

Repeat accuracy: is defined as the distribution of the end positions for 100 consecutive cycles.

Travel times: are pure movement times of the slide or the base body. Valve switching times, hose filling times, or PLC reaction times are not a part of this and are to be considered when cycle times are calculated.

Stroke: is the maximum nominal stroke of the unit. This can be shortened on both sides by the shock absorbers.

Layout or control calculation: For layout or sizing of the modules, we recommend using our software TOOLBOX, which can be downloaded online. Verifying the sizing of the selected unit is absolutely necessary, since otherwise overloading can result.

Ambient conditions: The modules are mainly designed for the use in clean ambient conditions. Please note that the life time of the modules can shorten if they are used in harsh ambient conditions, and that SCHUNK cannot assume liability in such cases. Please contact us for assistance.

Application Example

Pneumatic two-axis system with pillar assembly and gripper for assembly processes.

- 1 SOE Single Base Support
- 2 SLH Hollow Pillar
- 3 APEV Single Mounting Plate
- 4 KLM Linear Module
- 5 APL Adapter Plate
- 6 KLM Linear Module
- 7 ASG Adapter
- 8 KGG 2-Finger Small Components Gripper



SCHUNK offers more ...

The following components make the product KLM even more productive – the suitable addition for the highest functionality, flexibility, reliability, and controlled production.



ZZA Intermediate Stop



Fittings



Rod Lock

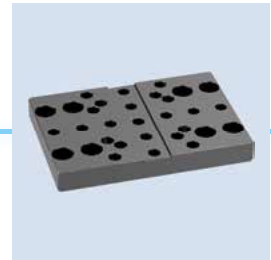

Adapter Plates



Pillar Assembly System SAS



Inductive Proximity Switches



Sensor Cables



Centering Strips



SDV-P Pressure Maintenance Valve

① Additional information regarding the products can be found on the following product pages or at www.schunk.com. Please contact us for further information: SCHUNK technical hotline +49-7133-103-2696

Options and special Information

Version rod lock: prevents the structure from falling in the event of a sudden loss of energy. This module can be combined as standard with many elements from the modular system. We can assist you with questions.

Forces and moments

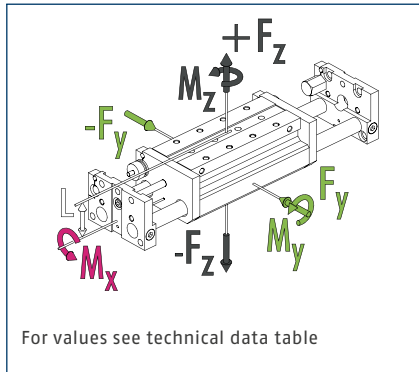

ⓘ The forces and moments shown here are maximum values for individual loading. If more than one force and/or moment occurs simultaneously, the case of application can be calculated by the TOOLBOX. The force F_y can just be calculated by the TOOLBOX.

Technical data

Description		KLM 25-H025	KLM 25-H042	KLM 25-H059
ID		0314010	0314011	0314012
Stroke	[mm]	25	42	59
Extend force	[N]	67	67	67
Retracted force	[N]	50	50	50
Repeat accuracy	[mm]	0.02	0.02	0.02
Piston diameter	[mm]	12	12	12
Bar diameter	[mm]	6	6	6
Min./max. operating pressure	[bar]	3/8	3/8	3/8
Nominal operating pressure	[bar]	6	6	6
Fluid consumption/10 mm stroke	[cm ³]	1.13	1.13	1.13
Overall length	[mm]	135	169	203
Protection class IP		40	40	40
Min./max. ambient temperature	[°C]	5/60	5/60	5/60
Weight	[kg]	0.5	0.58	0.66
Drive concept		Piston rod cylinders	Piston rod cylinders	Piston rod cylinders
Length L	[mm]	20	20	20
Moments M_x max./ M_y max./ M_z max.	[Nm]	3/10.5/10.5	1.9/9.5/9.5	1.3/8.5/8.5
Forces F_z max.	[N]	223	142	97

Main view

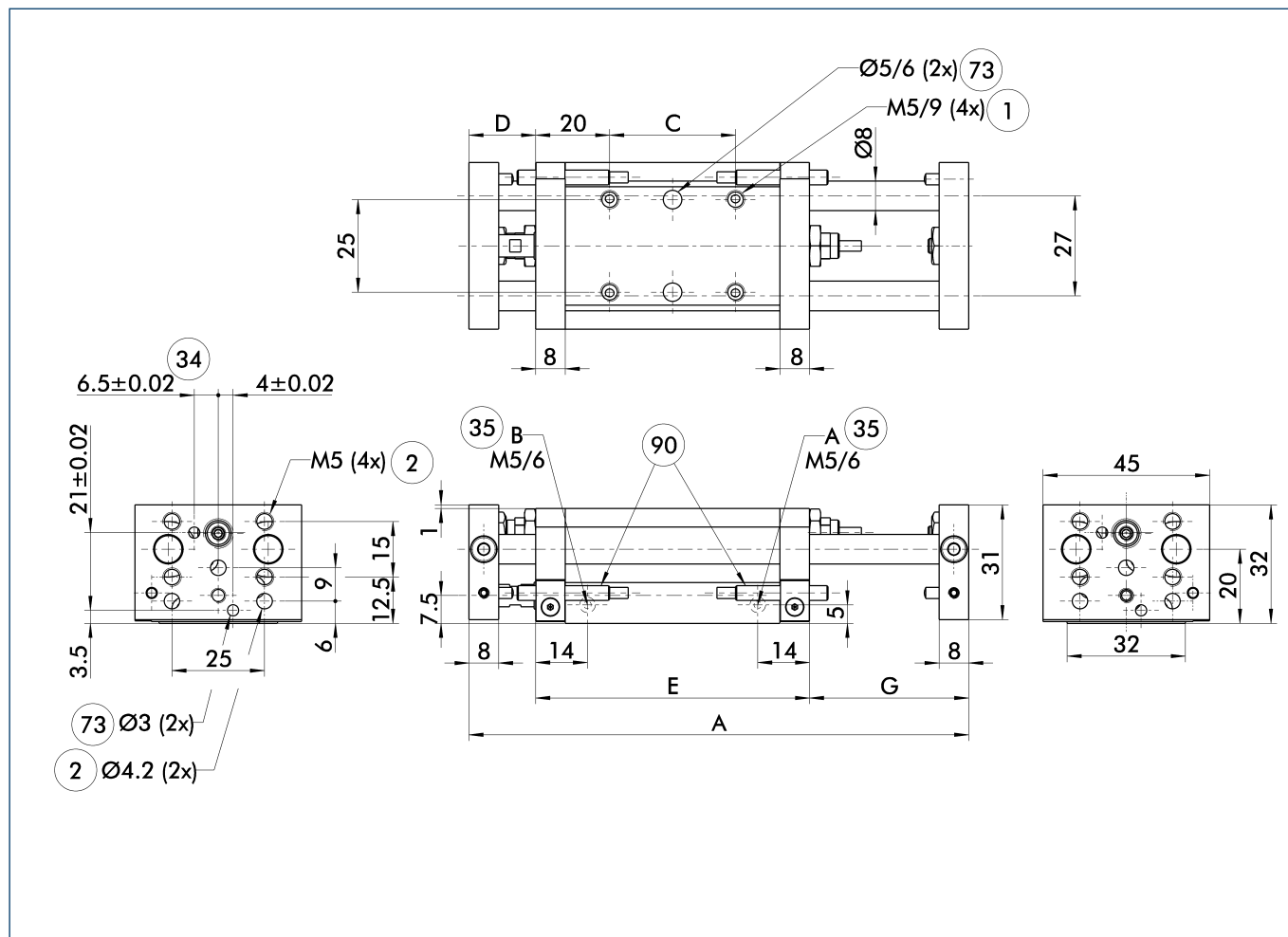

The linear module can be fastened either to the base body or the face plates. The structure can also optionally be fastened to either the face plates or the base body. This view shows the mounting of the module to the base body and the mounting of the structure to the face plates.

- A Main connection - linear unit extended
- B Main connection - linear unit retracted
- 1 Connection linear unit
- 2 Attachment connection
- 34 On both sides
- 35 Back side
- 73 Fit for centering pins
- 90 Inductive proximity switches

Description	A	C	Quantity C	D	E	G
	[mm]	[mm]		[mm]	[mm]	[mm]
KLM 25-H025	135	34	1	18	74	43
KLM 25-H042	169	34	1	18	91	60
KLM 25-H059	203	34	2	18	108	77

Fine adjustment

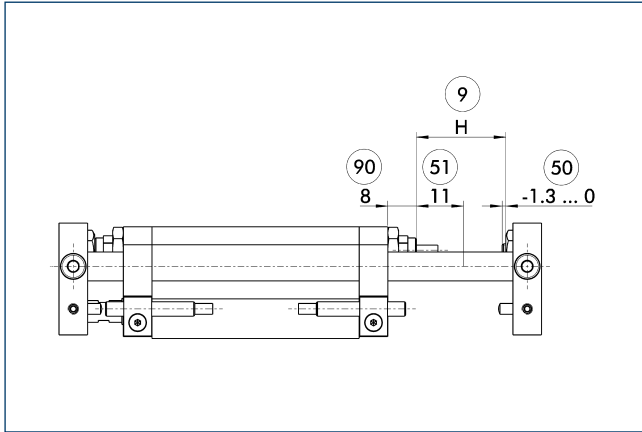

- ⑨ Effective stroke
- ⑤① Stroke adjustment range
- ⑤① Damping stroke adjustment
- ⑨① This dimension may not drop below this minimum value.

This illustration shows the possible fine adjustment of the stroke.

Attachment to a pillar assembly system

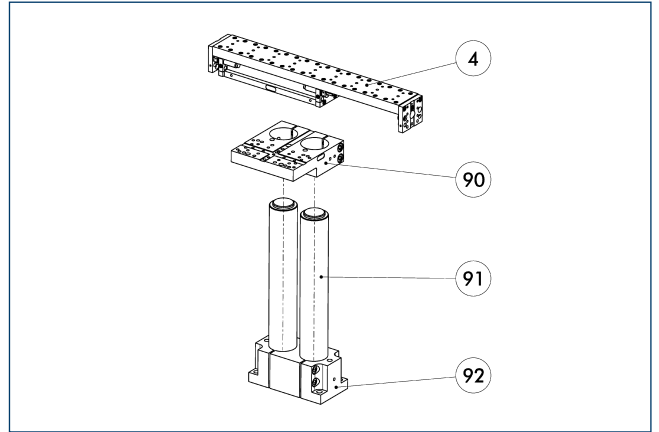

- ④ Linear unit
- ⑨① APDH double mounting plate
- ⑨① Pillars, hard-chromium plated, ground
- ⑨② SOD double socket

This unit can be attached to the pillar assembly system as standard. See the SCHUNK Kombibox software, which can be found online, for the right arrangement for your application.

Description	ID	Pillar diameter [mm]	Material
Pillar assembly system mounting plates			
APDH 20	0313614	20	Aluminum
APDV 20	0313616	20	Aluminum
APDV 35	0313896	35	Aluminum
APEH 20	0313613	20	Aluminum
APEH 35	0313893	35	Aluminum
APEV 20	0313615	20	Aluminum
APEV 35	0313895	35	Aluminum

ZZA intermediate stop on the piston side

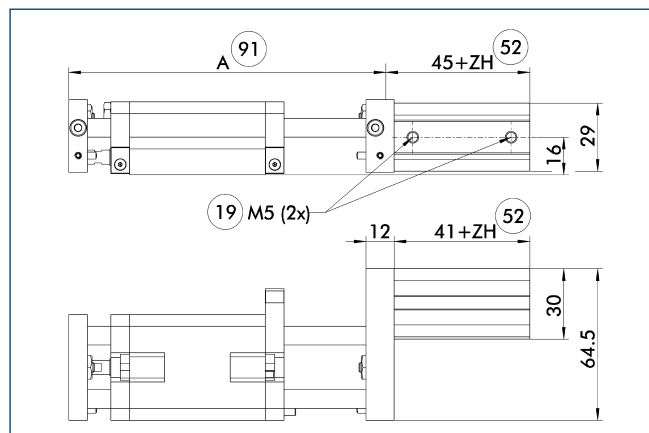

- ① 19 Air connection
- ② 52 Intermediate stroke
- ③ 91 Overall length "A", the variant without intermediate stroke (see measurement chart of stroke variants)

The intermediate position is measured from the respective end position. The intermediate position can be approached from both sides and can proceed in the original stroke direction. The holding force is the piston force of the intermediate stop less the piston force of the linear module.

Description	Holding force	With with 0 mm stroke	Weight per mm stroke
	[N]	[kg]	[kg]
Intermediate stop			
ZZA 28	54	0.2	0.002

④ Sample order KLM 25-H059-ZZA028-H15

ZZA intermediate stop on the piston rod side

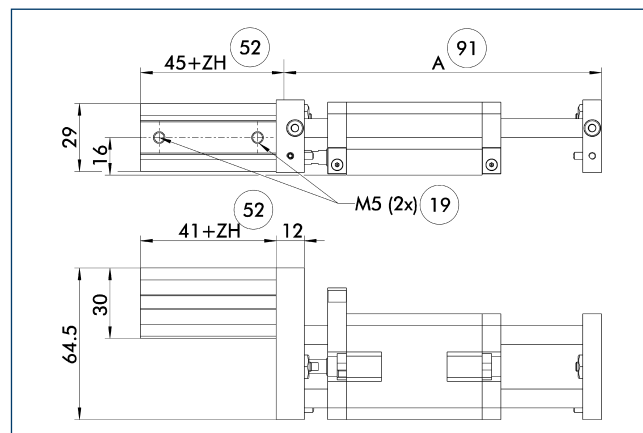

- ① 19 Air connection
- ② 52 Intermediate stroke
- ③ 91 Overall length "A", the variant without intermediate stroke (see measurement chart of stroke variants)

The intermediate position is measured from the respective end position. The intermediate position can be approached from both sides and can proceed in the original stroke direction. The holding force is the piston force of the intermediate stop less the piston force of the linear module.

Description	Holding force	With with 0 mm stroke	Weight per mm stroke
	[N]	[kg]	[kg]
Intermediate stop			
ZZA 29	54	0.2	0.002

④ Sample order KLM 25-H059-ZZA029-H15

Design – variant 1

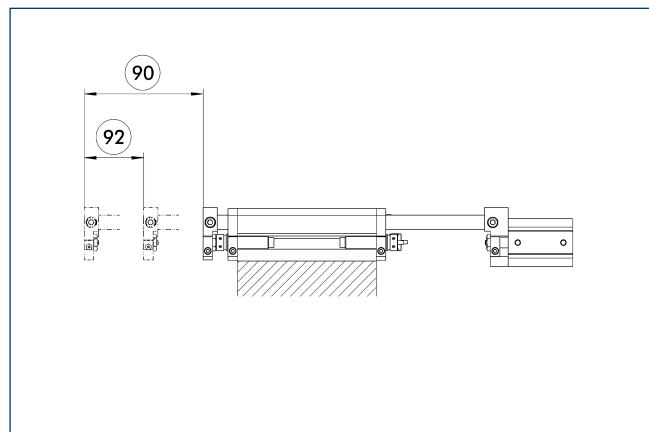

- ① 90 Nominal stroke
- ② 92 Intermediate stroke

The corresponding intermediate stroke (ZH) is calculated by subtracting the intermediate stop cylinder stroke from the nominal stroke of the module. The intermediate stroke adjustment is ±3 mm.

Design – variant 2

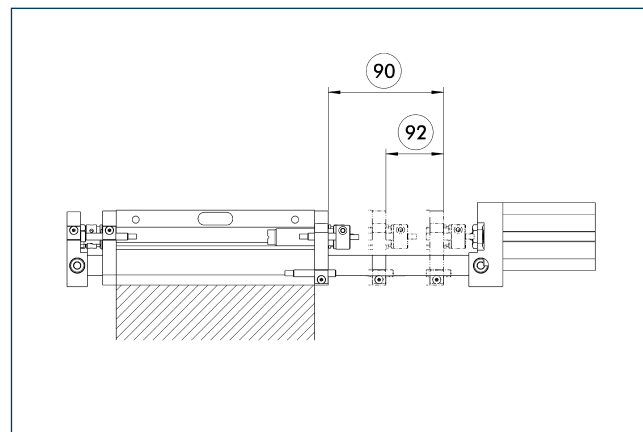

- ① 90 Nominal stroke
- ② 92 Intermediate stroke

The corresponding intermediate stroke (ZH) is calculated by subtracting the intermediate stop cylinder stroke from the nominal stroke of the module. The intermediate stroke adjustment is ±3 mm.

Modular assembly automation

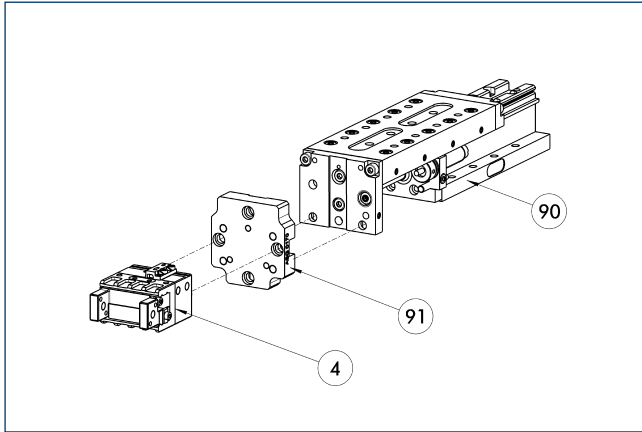

- ④ Grippers
- ⑨① ASG adapter plate
- ⑨① CLM/KLM/LM/ELM/ELS/HLM linear modules

Grippers and linear modules can be combined with the standard modular system for modular assembly automation. For more information see our main catalog "Modular Assembly Automation".

Inductive proximity switches

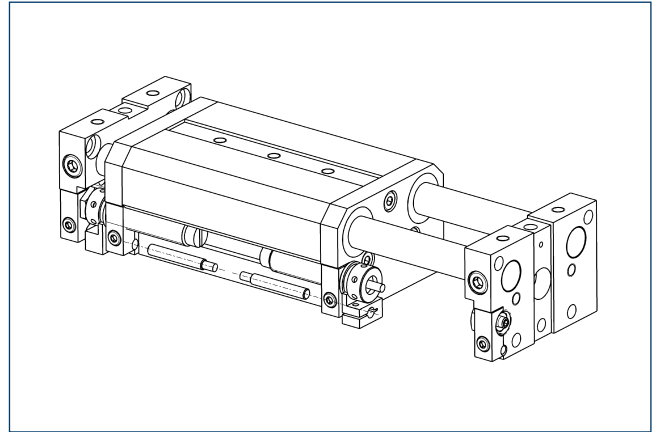

Directly mounted end position monitoring.

Description	ID	Often combined
Inductive proximity switches		
IN 40-S-M12	0301574	
IN 40-S-M8	0301474	●
INK 40-S	0301555	
Inductive proximity switch with lateral outlet		
IN 40-S-M12-SA	0301577	
IN 40-S-M8-SA	0301473	●
INK 40-S-SA	0301565	
Cable extension		
KV BG12-SG12 3P-0030-PNP	0301999	
KV BG12-SG12 3P-0060-PNP	0301998	
KV BW08-SG08 3P-0030-PNP	0301495	
KV BW08-SG08 3P-0100-PNP	0301496	
KV BW08-SG08 3P-0200-PNP	0301497	●
KV BW12-SG12 3P-0030-PNP	0301595	
KV BW12-SG12 3P-0100-PNP	0301596	
KV BW12-SG12 3P-0200-PNP	0301597	
Clip for plug/socket		
CLI-M12	0301464	
CLI-M8	0301463	
Connection cables		
KA BG08-L 3P-0300-PNP	0301622	●
KA BG08-L 3P-0500-PNP	0301623	
KA BG12-L 3P-0500-PNP	30016369	
KA BW08-L 3P-0300-PNP	0301594	
KA BW08-L 3P-0500-PNP	0301502	
KA BW12-L 3P-0300-PNP	0301503	
KA BW12-L 3P-0500-PNP	0301507	
Sensor distributor		
V2-M12	0301776	●
V2-M8	0301775	●
V4-M12	0301747	
V4-M8	0301746	
V8-M12	0301752	
V8-M8	0301751	

- ① Two sensors (closer/S) are required for each unit and extension cables are available as an option. For sensor cables, note the minimum permissible bending radii. These are generally 35 mm.

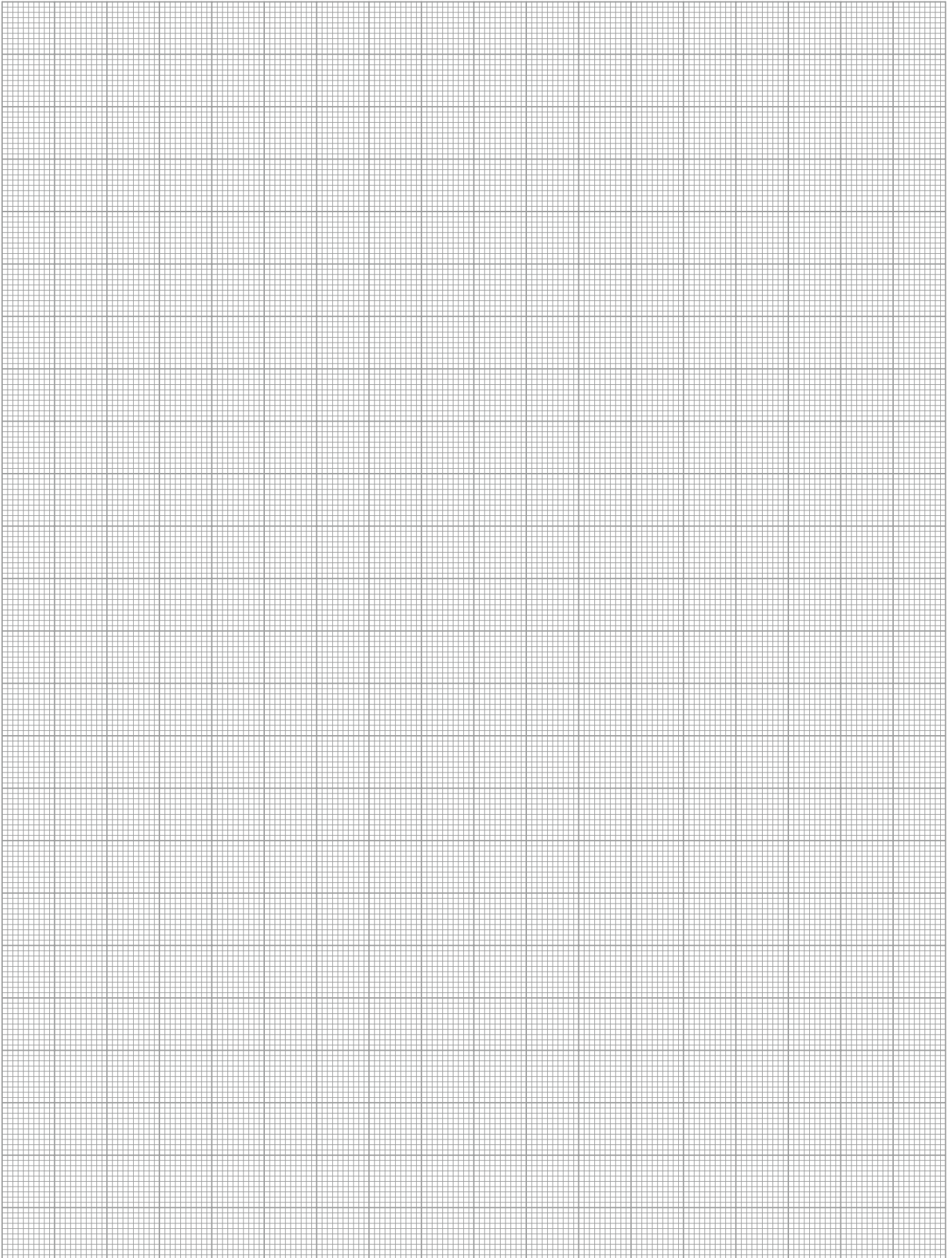

Forces and moments

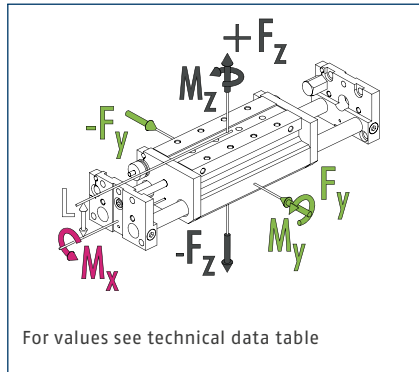

ⓘ The forces and moments shown here are maximum values for individual loading. If more than one force and/or moment occurs simultaneously, the case of application can be calculated by the TOOLBOX. The force F_y can just be calculated by the TOOLBOX.

Technical data

Description		KLM 50-H013	KLM 50-H025	KLM 50-H038	KLM 50-H050	KLM 50-H063	KLM 50-H075
ID		0314013	0314014	0314015	0314016	0314017	0314018
Stroke	[mm]	13	25	38	50	63	75
Extend force	[N]	120	120	120	120	120	120
Retracted force	[N]	103	103	103	103	103	103
Repeat accuracy	[mm]	0.02	0.02	0.02	0.02	0.02	0.02
Piston diameter	[mm]	16	16	16	16	16	16
Bar diameter	[mm]	6	6	6	6	6	6
Min./max. operating pressure	[bar]	3/8	3/8	3/8	3/8	3/8	3/8
Nominal operating pressure	[bar]	6	6	6	6	6	6
Fluid consumption/10 mm stroke	[cm ³]	2	2	2	2	2	2
Overall length	[mm]	150	150	200	200	250	250
Protection class IP		40	40	40	40	40	40
Min./max. ambient temperature	[°C]	5/60	5/60	5/60	5/60	5/60	5/60
Weight	[kg]	1.3	1.3	1.5	1.5	1.7	1.7
Drive concept		Piston rod cylinders	Piston rod cylinders	Piston rod cylinders	Piston rod cylinders	Piston rod cylinders	Piston rod cylinders
Length L	[mm]	32.5	32.5	32.5	32.5	32.5	32.5
Moments M_x max./ M_y max./ M_z max.	[Nm]	11.4/23/23	11.4/23/23	9.2/30.5/30.5	9.2/30.5/30.5	6.5/29/29	6.5/29/29
Forces F_z max.	[N]	569	569	461	461	324	324
Options and their characteristics							
Dust-tight version		KLM 50-H013-SD	KLM 50-H025-SD	KLM 50-H038-SD	KLM 50-H050-SD	KLM 50-H063-SD	KLM 50-H075-SD
ID		0314640	0314641	0314642	0314643	0314644	0314645
Protection class IP		50	50	50	50	50	50
Rod lock version			KLM 50-H025-ASP	KLM 50-H038-ASP	KLM 50-H050-ASP	KLM 50-H063-ASP	KLM 50-H075-ASP
ID			0314414	0314415	0314416	0314417	0314418
Stroke loss of nominal stroke (on the rod side)	[mm]		10	10	10	10	10
Weight	[kg]		1.34	1.54	1.54	1.74	1.74
Static holding force	[N]		180	180	180	180	180
Max. axial backlash of the clamping	[mm]		0.2	0.2	0.2	0.2	0.2
Min. release air pressure	[bar]		3	3	3	3	3

Description		KLM 50-H088	KLM 50-H100	KLM 50-H113	KLM 50-H125
ID		0314019	0314020	0314021	0314022
Stroke	[mm]	88	100	113	125
Extend force	[N]	120	120	120	120
Retracted force	[N]	103	103	103	103
Repeat accuracy	[mm]	0.02	0.02	0.02	0.02
Piston diameter	[mm]	16	16	16	16
Bar diameter	[mm]	6	6	6	6
Min./max. operating pressure	[bar]	3/8	3/8	3/8	3/8
Nominal operating pressure	[bar]	6	6	6	6
Fluid consumption/10 mm stroke	[cm ³]	2	2	2	2
Overall length	[mm]	300	300	350	350
Protection class IP		40	40	40	40
Min./max. ambient temperature	[°C]	5/60	5/60	5/60	5/60
Weight	[kg]	1.9	1.9	2.1	2.1
Drive concept		Piston rod cylinders	Piston rod cylinders	Piston rod cylinders	Piston rod cylinders
Length L	[mm]	32.5	32.5	32.5	32.5
Moments M_x max./ M_y max./ M_z max.	[Nm]	4.5/26.5/26.5	4.5/26.5/26.5	3.2/23.5/23.5	3.2/23.5/23.5
Forces F_z max.	[N]	224	224	164	164
Options and their characteristics					
Dust-tight version		KLM 50-H088-SD	KLM 50-H100-SD	KLM 50-H113-SD	KLM 50-H125-SD
ID		0314646	0314647	0314648	0314649
Protection class IP		50	50	50	50
Rod lock version		KLM 50-H088-ASP	KLM 50-H100-ASP	KLM 50-H113-ASP	KLM 50-H125-ASP
ID		0314419	0314420	0314421	0314422
Stroke loss of nominal stroke (on the rod side)	[mm]	10	10	10	10
Weight	[kg]	1.94	1.94	2.14	2.14
Static holding force	[N]	180	180	180	180
Max. axial backlash of the clamping	[mm]	0.2	0.2	0.2	0.2
Min. release air pressure	[bar]	3	3	3	3

Main view

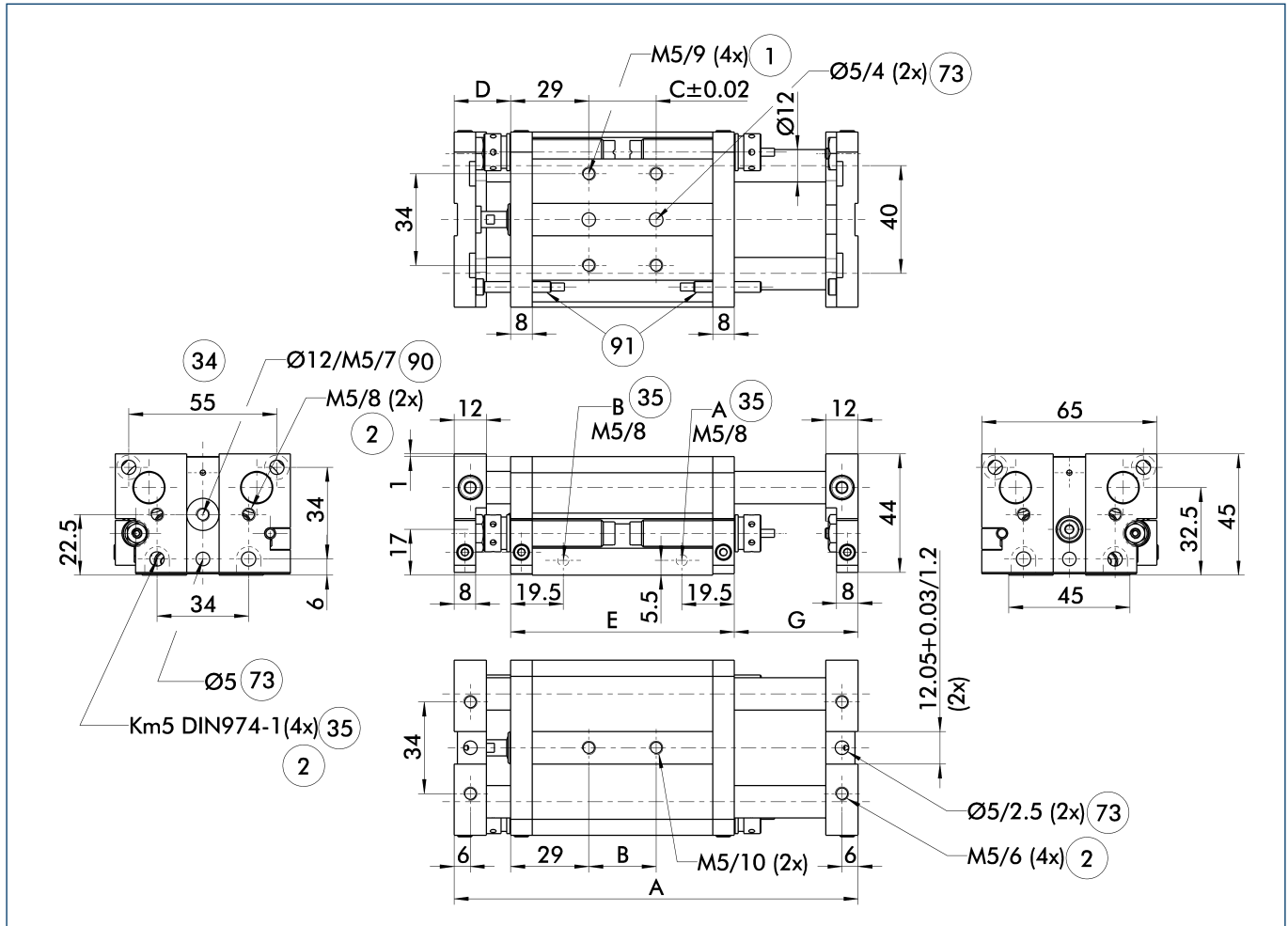

The linear module can be fastened either to the base body or the face plates. The structure can also optionally be fastened to either the face plates or the base body. This view shows the mounting of the module to the base body and the mounting of the structure to the face plates.

- A Main connection - linear unit extended
- B Main connection - linear unit retracted
- 1 Connection linear unit
- 2 Attachment connection
- 34 On both sides
- 35 Back side
- 73 Fit for centering pins
- 90 Through-holes in the face plate and thread in the base body (only single sided)
- 91 Inductive proximity switches

Description	A [mm]	B [mm]	Quantity B	C [mm]	Quantity C	D [mm]	E [mm]	G [mm]
KLM 50-H013	150	25	1	25	1	21	83	46
KLM 50-H025	150	25	1	25	1	21	83	46
KLM 50-H038	200	25	2	25	2	21	108	71
KLM 50-H050	200	25	2	25	2	21	108	71
KLM 50-H063	250	25	3	25	3	21	133	96
KLM 50-H075	250	25	3	25	3	21	133	96
KLM 50-H088	300	25	4	25	4	21	158	121
KLM 50-H100	300	25	4	25	4	21	158	121
KLM 50-H113	350	25	5	25	5	21	183	146
KLM 50-H125	350	25	5	25	5	21	183	146

Dust-tight version

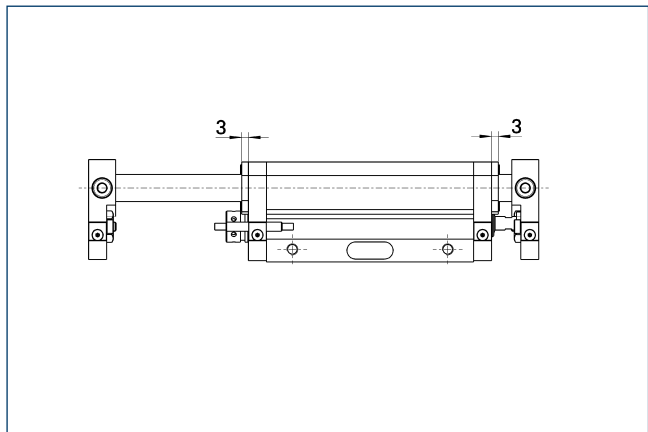

The dust cover option increases the protection against external particles.

Fine adjustment

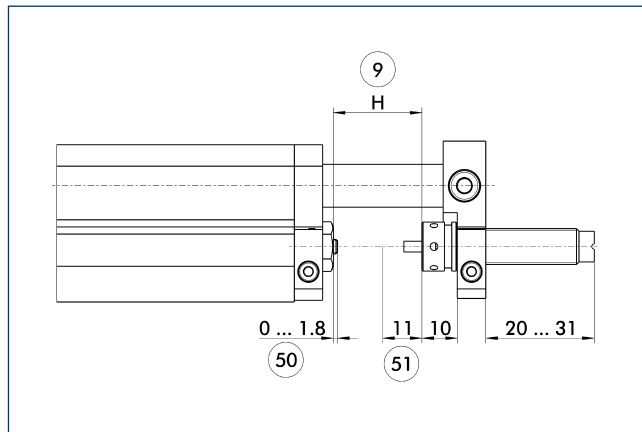

- ⑨ Effective stroke
- ⑤① Stroke adjustment range
- ⑤① Damping stroke adjustment range

Shock absorbers can be mounted either on the base body or on the face plates. This illustration shows the mounting on the face plates and the possibility of stroke fine adjustment.

Fine adjustment

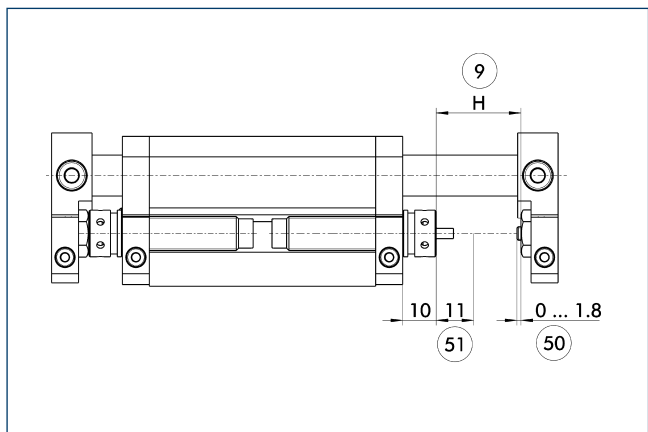

- ⑨ Effective stroke
- ⑤① Stroke adjustment range
- ⑤① Damping stroke adjustment range

Shock absorbers can be mounted either on the base body or on the face plates. This illustration shows the mounting on the base body and the possibility of stroke fine adjustment.

Rod lock

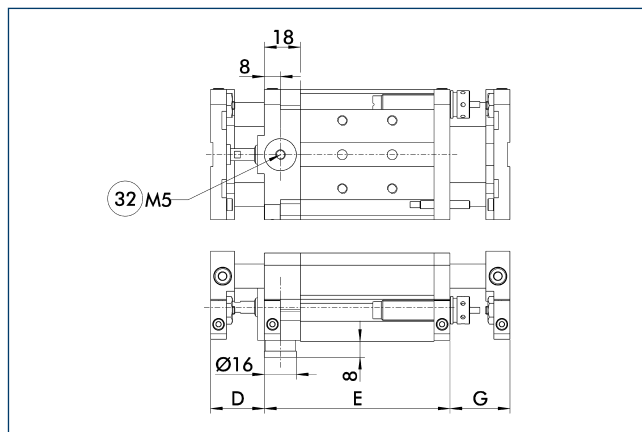

- ③② Pneumatic connection for holding brake

The rod lock prevents weights from falling in the event of energy loss, such as emergency stop situations. The rod lock can also be retrofitted, but this will reduce the effective stroke.

Description	D	E	G
	[mm]	[mm]	[mm]
KLM 50-H025-ASP	21	103	36
KLM 50-H038-ASP	21	118	61
KLM 50-H050-ASP	21	118	61
KLM 50-H063-ASP	21	143	86
KLM 50-H075-ASP	21	143	86
KLM 50-H088-ASP	21	168	111
KLM 50-H100-ASP	21	168	111
KLM 50-H113-ASP	21	193	136
KLM 50-H125-ASP	21	193	136



Attachment to a pillar assembly system

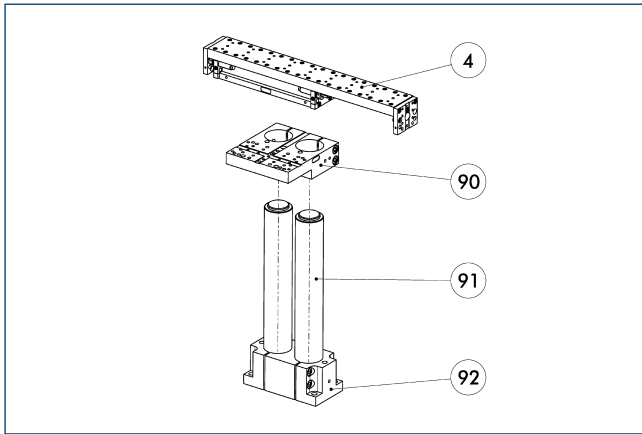

- ④ Linear unit
- ⑨① Pillars, hard-chromium plated, ground
- ⑨② SOD double socket
- ⑨① APDH double mounting plate

This unit can be attached to the pillar assembly system as standard. See the SCHUNK Kombibox software, which can be found online, for the right arrangement for your application.

Description	ID	Pillar diameter [mm]	Material
Pillar assembly system mounting plates			
APDH 85	0313414	55	Aluminum
APDV 35	0313896	35	Aluminum
APDV 85	0313416	55	Aluminum
APEH 35	0313893	35	Aluminum
APEH 85	0313413	55	Aluminum
APEV 35	0313895	35	Aluminum
APEV 85	0313415	55	Aluminum

ZZA intermediate stop on the piston side

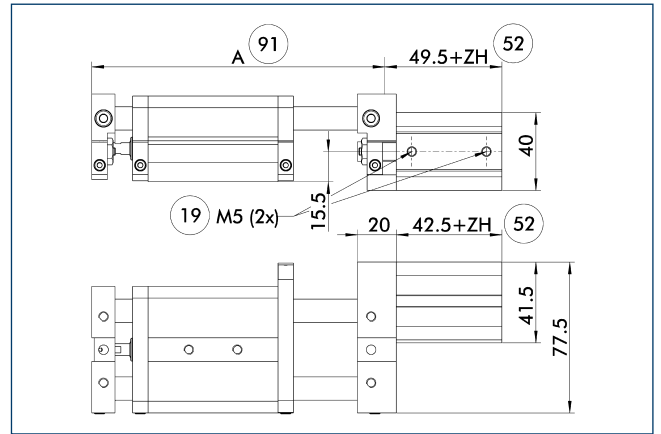

- ①⑨ Air connection
- ⑤② Intermediate stroke
- ⑨① Overall length "A", the variant without intermediate stroke (see measurement chart of stroke variants)

The intermediate position is measured from the respective end position. The intermediate position can be approached from both sides and can proceed in the original stroke direction. The holding force is the piston force of the intermediate stop less the piston force of the linear module.

Description	Holding force [N]	With with 0 mm stroke [kg]	Weight per mm stroke [kg]
Intermediate stop			
ZZA 55	175	0.35	0.003

- ① Sample order KLM 50-H100-ZZA055-H30

ZZA intermediate stop on the piston rod side

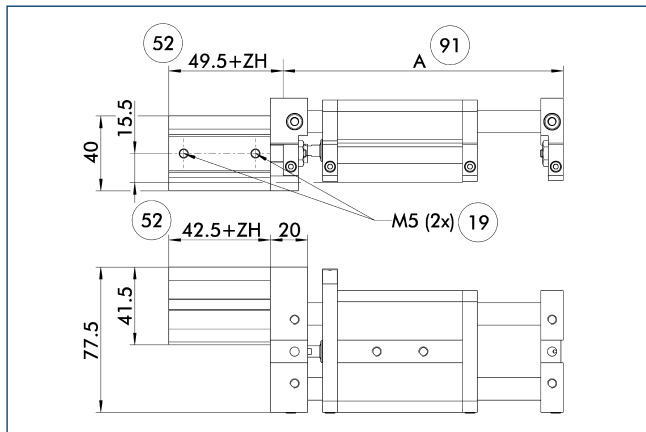

- ①⑨ Air connection
- ①⑤ Intermediate stroke
- ①⑨ Overall length "A", the variant without intermediate stroke (see measurement chart of stroke variants)

The intermediate position is measured from the respective end position. The intermediate position can be approached from both sides and can proceed in the original stroke direction. The holding force is the piston force of the intermediate stop less the piston force of the linear module.

Description	Holding force	With with 0 mm stroke	Weight per mm stroke
	[N]	[kg]	[kg]
Intermediate stop			
ZZA 56	175	0.35	0.003

① Sample order KLM 50-H100-ZZA056-H30

Design – variant 1

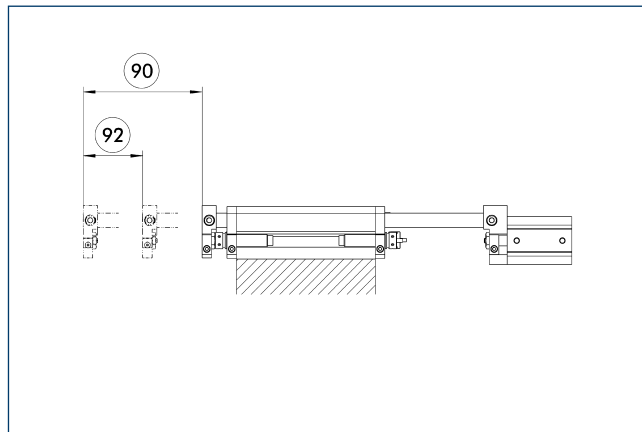

- ①⑨ Nominal stroke
- ①⑤ Intermediate stroke

The corresponding intermediate stroke (ZH) is calculated by subtracting the intermediate stop cylinder stroke from the nominal stroke of the module. The intermediate stroke adjustment is ±3 mm.

Design – variant 2

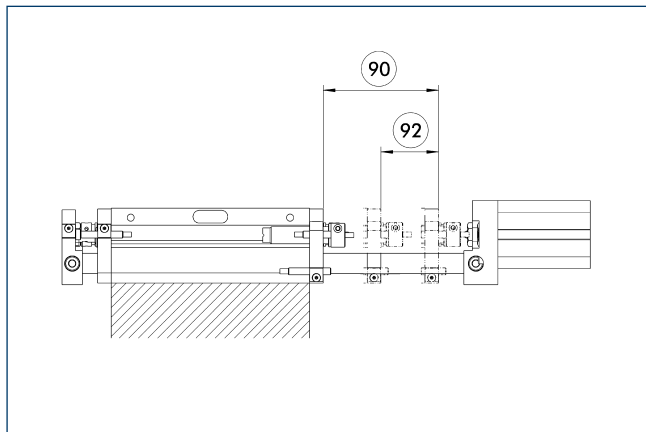

- ①⑨ Nominal stroke
- ①⑤ Intermediate stroke

The corresponding intermediate stroke (ZH) is calculated by subtracting the intermediate stop cylinder stroke from the nominal stroke of the module. The intermediate stroke adjustment is ±3 mm.

Modular assembly automation

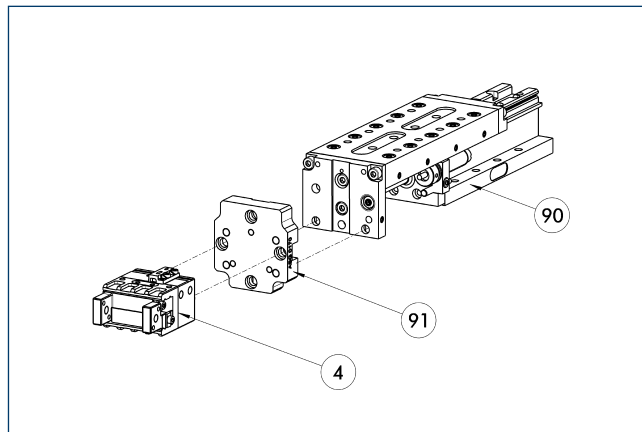

- ④ Grippers
- ①⑤ CLM/KLM/LM/ELM/ELS/HLM linear modules
- ①⑨ ASG adapter plate

Grippers and linear modules can be combined with the standard modular system for modular assembly automation. For more information see our main catalog "Modular Assembly Automation".

Inductive proximity switches

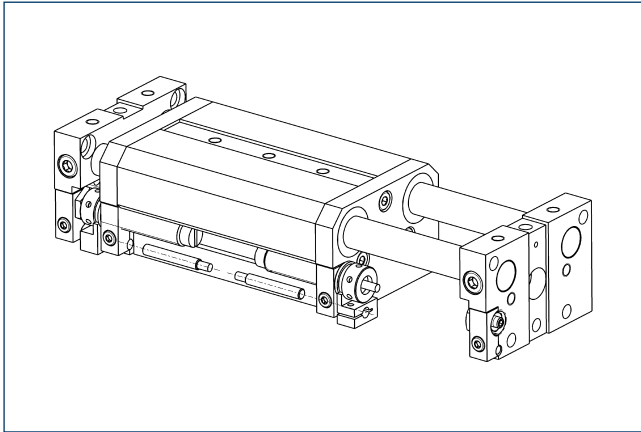

Directly mounted end position monitoring.

Description	ID	Often combined
Inductive proximity switches		
IN 40-S-M12	0301574	
IN 40-S-M8	0301474	●
INK 40-S	0301555	
Inductive proximity switch with lateral outlet		
IN 40-S-M12-SA	0301577	
IN 40-S-M8-SA	0301473	●
INK 40-S-SA	0301565	
Cable extension		
KV BG12-SG12 3P-0030-PNP	0301999	
KV BG12-SG12 3P-0060-PNP	0301998	
KV BW08-SG08 3P-0030-PNP	0301495	
KV BW08-SG08 3P-0100-PNP	0301496	
KV BW08-SG08 3P-0200-PNP	0301497	●
KV BW12-SG12 3P-0030-PNP	0301595	
KV BW12-SG12 3P-0100-PNP	0301596	
KV BW12-SG12 3P-0200-PNP	0301597	
Clip for plug/socket		
CLI-M12	0301464	
CLI-M8	0301463	
Connection cables		
KA BG08-L 3P-0300-PNP	0301622	●
KA BG08-L 3P-0500-PNP	0301623	
KA BG12-L 3P-0500-PNP	30016369	
KA BW08-L 3P-0300-PNP	0301594	
KA BW08-L 3P-0500-PNP	0301502	
KA BW12-L 3P-0300-PNP	0301503	
KA BW12-L 3P-0500-PNP	0301507	
Sensor distributor		
V2-M12	0301776	●
V2-M8	0301775	●
V4-M12	0301747	
V4-M8	0301746	
V8-M12	0301752	
V8-M8	0301751	

- ① Two sensors (closer/S) are required for each unit and extension cables are available as an option. For sensor cables, note the minimum permissible bending radii. These are generally 35 mm.

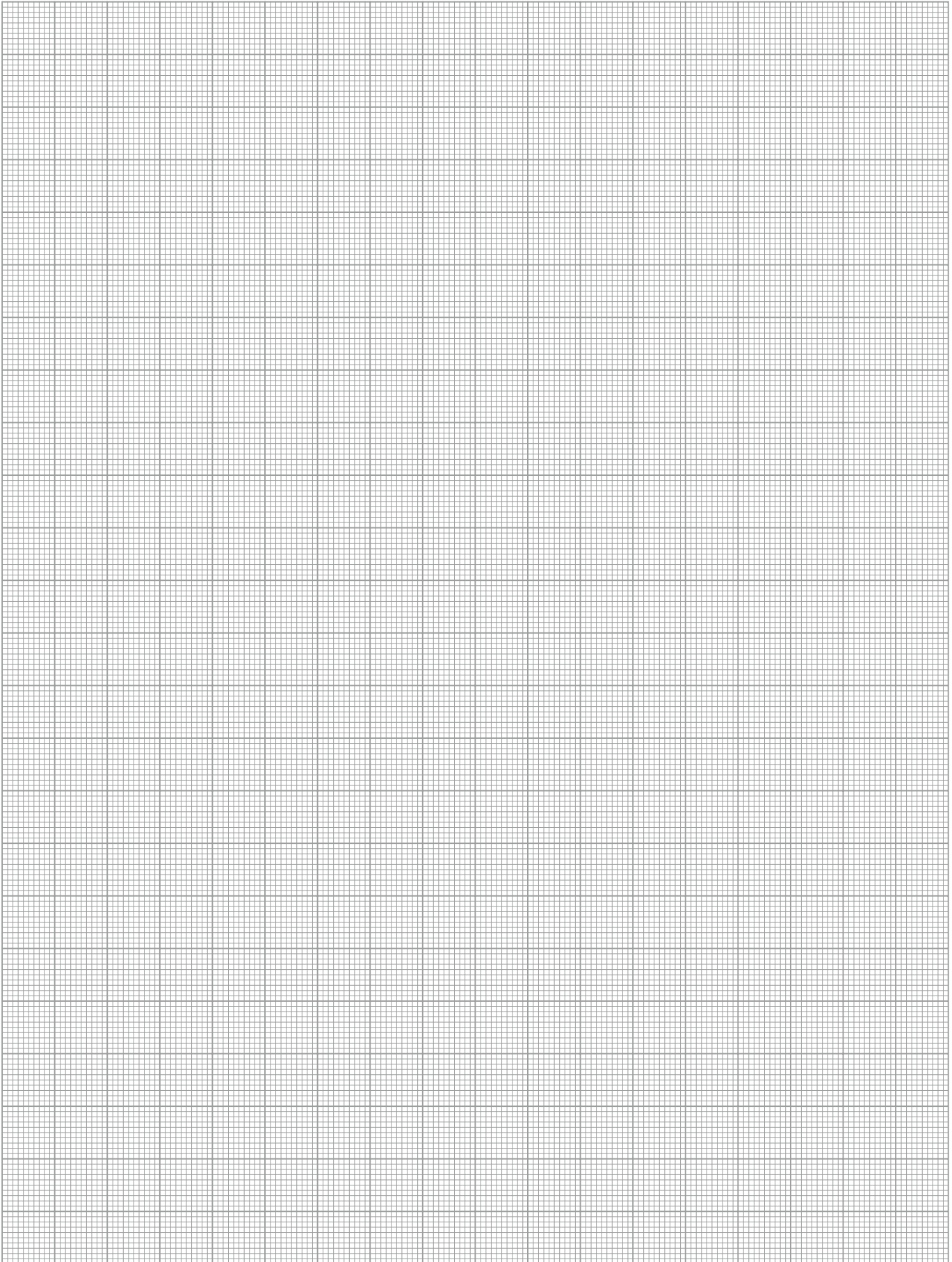

Forces and moments

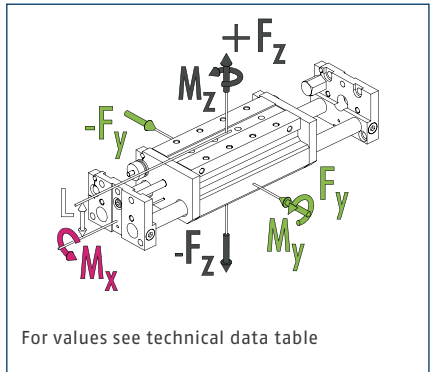

ⓘ The forces and moments shown here are maximum values for individual loading. If more than one force and/or moment occurs simultaneously, the case of application can be calculated by the TOOLBOX. The force F_y can just be calculated by the TOOLBOX.

Technical data

Description		KLM 100-H025	KLM 100-H050	KLM 100-H075	KLM 100-H100	KLM 100-H125	KLM 100-H150
ID		0314023	0314024	0314025	0314026	0314027	0314028
Stroke	[mm]	25	50	75	100	125	150
Extend force	[N]	294	294	294	294	294	294
Retracted force	[N]	226	226	226	226	226	226
Repeat accuracy	[mm]	0.03	0.03	0.03	0.03	0.03	0.03
Piston diameter	[mm]	25	25	25	25	25	25
Bar diameter	[mm]	12	12	12	12	12	12
Min./max. operating pressure	[bar]	3/8	3/8	3/8	3/8	3/8	3/8
Nominal operating pressure	[bar]	6	6	6	6	6	6
Fluid consumption/10 mm stroke	[cm ³]	4.9	4.9	4.9	4.9	4.9	4.9
Overall length	[mm]	170	270	270	370	370	470
Protection class IP		40	40	40	40	40	40
Min./max. ambient temperature	[°C]	5/60	5/60	5/60	5/60	5/60	5/60
Weight	[kg]	2.3	3	3	3.7	3.7	4.4
Drive concept		Piston rod cylinders	Piston rod cylinders	Piston rod cylinders	Piston rod cylinders	Piston rod cylinders	Piston rod cylinders
Length L	[mm]	44	44	44	44	44	44
Moments M_x max./ M_y max./ M_z max.	[Nm]	25.5/32.5/32.5	13.5/57.5/57.5	13.5/57.5/57.5	11.5/58.5/58.5	11.5/58.5/58.5	7.3/52/52
Forces F_z max.	[N]	999	529	592	449	449	284
Options and their characteristics							
Dust-tight version		KLM 100-H025-SD	KLM 100-H050-SD	KLM 100-H075-SD	KLM 100-H100-SD	KLM 100-H125-SD	KLM 100-H150-SD
ID		0314790	0314791	0314792	0314793	0314794	0314795
Protection class IP		50	50	50	50	50	50
Rod lock version			KLM 100-H050-ASP	KLM 100-H075-ASP	KLM 100-H100-ASP	KLM 100-H125-ASP	KLM 100-H150-ASP
ID			0314424	0314425	0314426	0314427	0314428
Stroke loss of nominal stroke (on the rod side)	[mm]		12	12	12	12	12
Weight	[kg]		3.08	3.08	3.78	3.78	4.48
Static holding force	[N]		600	600	600	600	600
Max. axial backlash of the clamping	[mm]		0.3	0.3	0.3	0.3	0.3
Min. release air pressure	[bar]		3	3	3	3	3

Description		KLM 100-H175	KLM 100-H200	KLM 100-H225
ID		0314029	0314030	0314031
Stroke	[mm]	175	200	225
Extend force	[N]	294	294	294
Retracted force	[N]	226	226	226
Repeat accuracy	[mm]	0.03	0.03	0.03
Piston diameter	[mm]	25	25	25
Bar diameter	[mm]	12	12	12
Min./max. operating pressure	[bar]	3/8	3/8	3/8
Nominal operating pressure	[bar]	6	6	6
Fluid consumption/10 mm stroke	[cm ³]	4.9	4.9	4.9
Overall length	[mm]	470	570	570
Protection class IP		40	40	40
Min./max. ambient temperature	[°C]	5/60	5/60	5/60
Weight	[kg]	4.4	5.1	5.1
Drive concept		Piston rod cylinders	Piston rod cylinders	Piston rod cylinders
Length L	[mm]	44	44	44
Moments M_x max./ M_y max./ M_z max.	[Nm]	7.3/52/52	5/44.5/44.5	5/44.5/44.5
Forces F_z max.	[N]	284	194	194
Options and their characteristics				
Dust-tight version		KLM 100-H175-SD	KLM 100-H200-SD	KLM 100-H225-SD
ID		0314796	0314797	0314798
Protection class IP		50	50	50
Rod lock version		KLM 100-H175-ASP	KLM 100-H200-ASP	KLM 100-H225-ASP
ID		0314429	0314430	0314431
Stroke loss of nominal stroke (on the rod side)	[mm]	12	12	12
Weight	[kg]	4.48	5.18	5.18
Static holding force	[N]	600	600	600
Max. axial backlash of the clamping	[mm]	0.3	0.3	0.3
Min. release air pressure	[bar]	3	3	3

Main view

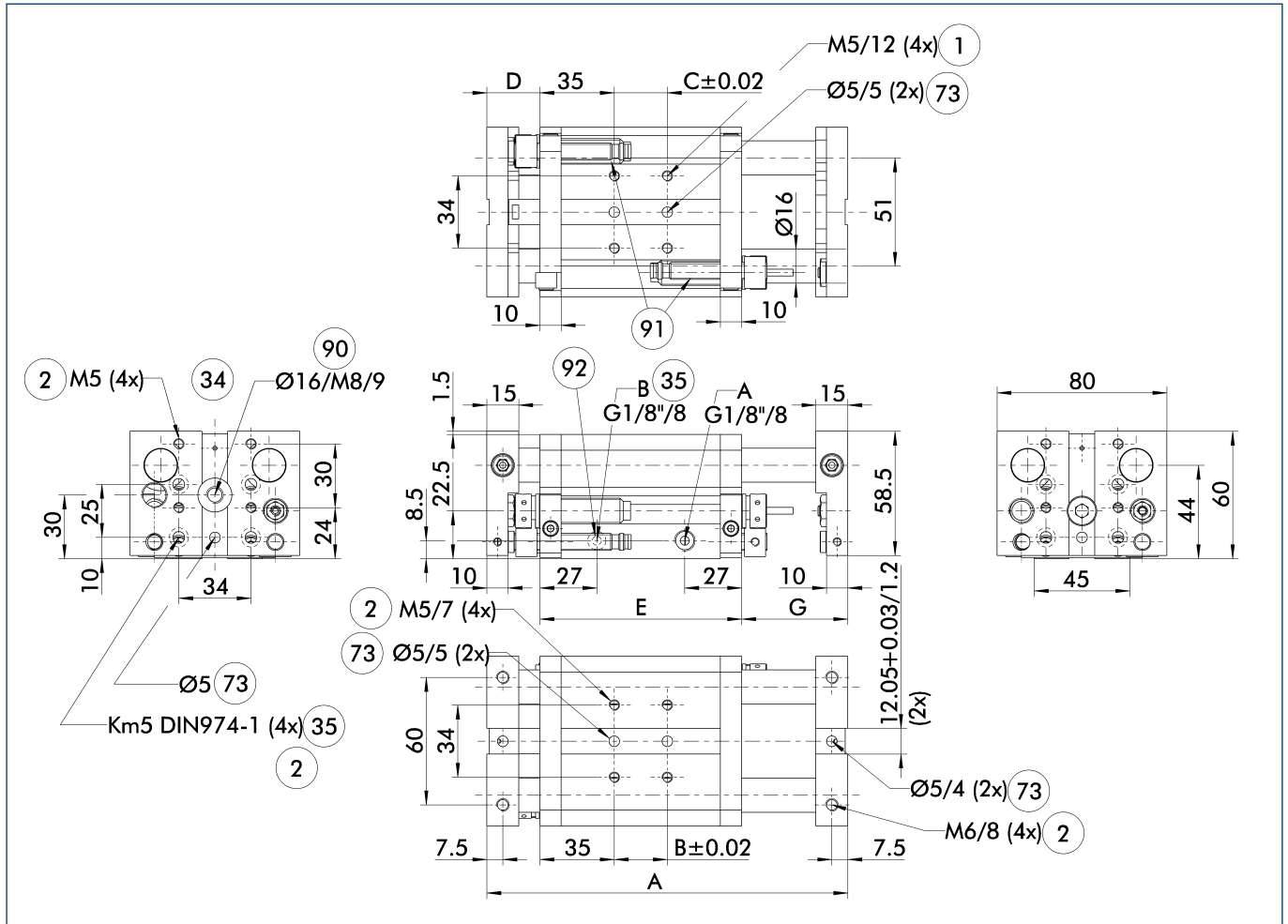

The linear module can be fastened either to the base body or the face plates. The structure can also optionally be fastened to either the face plates or the base body. This view shows the mounting of the module to the base body and the mounting of the structure to the face plates.

- A Main connection - linear unit extended
- B Main connection - linear unit retracted
- ① Connection linear unit
- ② Attachment connection
- ③④ On both sides
- ③⑤ Back side
- ⑦③ Fit for centering pins
- ⑨⑩ Through-holes in the face plate and thread in the base body (only single sided)
- ⑨① Inductive proximity switches
- ⑨② Air connection "B" only for stroke 025 at the rear

Description	A	B	Quantity B	C	Quantity C	D	E	G
	[mm]	[mm]		[mm]		[mm]	[mm]	[mm]
KLM 100-H025	170	25	1	25	1	25	95	50
KLM 100-H050	270	25	3	25	3	25	145	100
KLM 100-H075	270	25	3	25	3	25	145	100
KLM 100-H100	370	25	5	25	5	25	195	150
KLM 100-H125	370	25	5	25	5	25	195	150
KLM 100-H150	470	25	7	25	7	25	245	200
KLM 100-H175	470	25	7	25	7	25	245	200
KLM 100-H200	570	25	9	25	9	25	295	250
KLM 100-H225	570	25	9	25	9	25	295	250

Dust-tight version

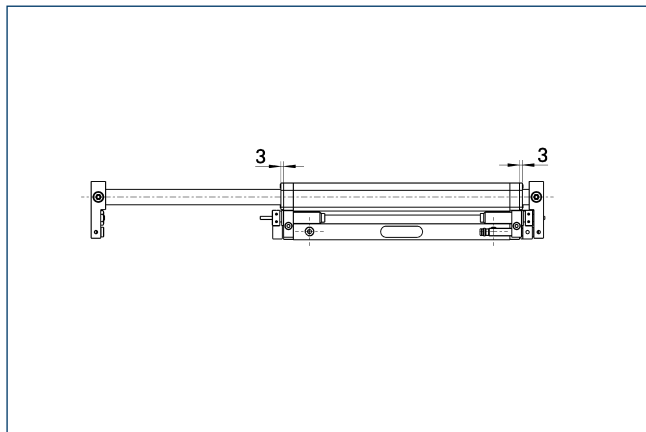

The dust cover option increases the protection against external particles.

Fine adjustment

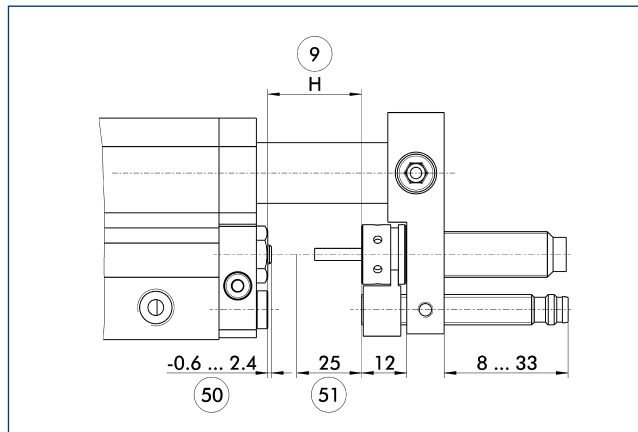

- ⑨ Effective stroke
- ⑤① Stroke adjustment range
- ⑤① Damping stroke adjustment range

Shock absorbers can be mounted either on the base body or on the face plates. This illustration shows the mounting on the face plates and the possibility of stroke fine adjustment.

Fine adjustment

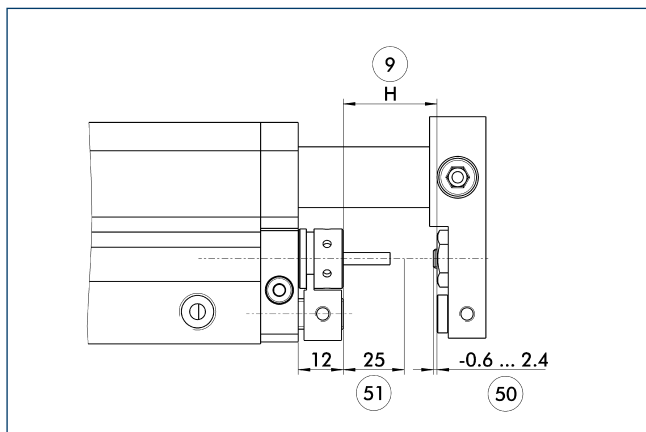

- ⑨ Effective stroke
- ⑤① Stroke adjustment range
- ⑤① Damping stroke adjustment range

Shock absorbers can be mounted either on the base body or on the face plates. This illustration shows the mounting on the base body and the possibility of stroke fine adjustment.

Rod lock

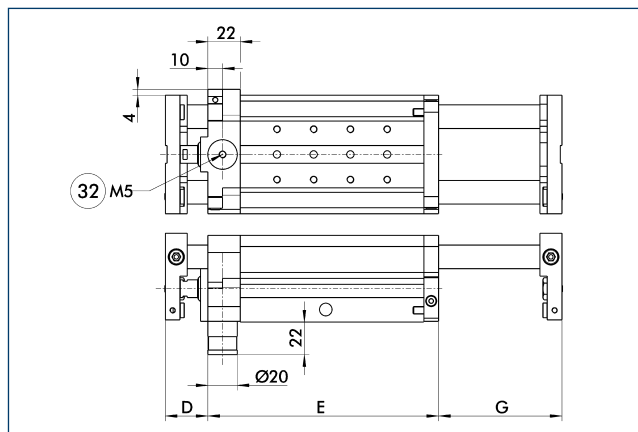

- ③② Pneumatic connection for holding brake

The rod lock prevents weights from falling in the event of energy loss, such as emergency stop situations. The rod lock can also be retrofitted, but this will reduce the effective stroke.

Description	D	E	G
	[mm]	[mm]	[mm]
KLM 100-H050-ASP	25	157	88
KLM 100-H075-ASP	25	157	88
KLM 100-H100-ASP	25	207	138
KLM 100-H125-ASP	25	207	138
KLM 100-H150-ASP	25	257	198
KLM 100-H175-ASP	25	257	198
KLM 100-H200-ASP	25	307	238
KLM 100-H225-ASP	25	307	238

Attachment to a pillar assembly system

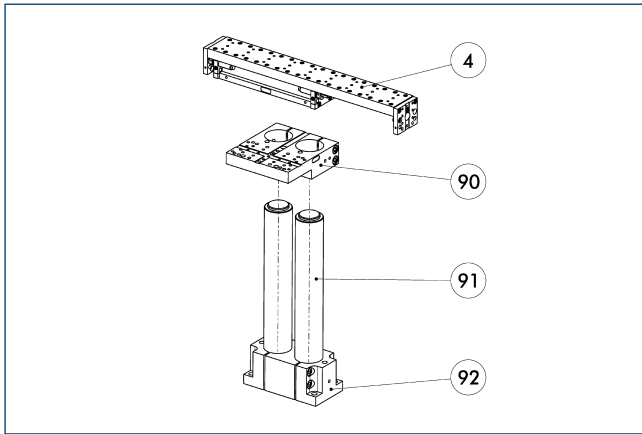

- ④ Linear unit
- ⑨① Pillars, hard-chromium plated, ground
- ⑨② SOD double socket
- ⑨① APDH double mounting plate

This unit can be attached to the pillar assembly system as standard. See the SCHUNK Kombibox software, which can be found online, for the right arrangement for your application.

Description	ID	Pillar diameter [mm]	Material
Pillar assembly system mounting plates			
APDH 85	0313414	55	Aluminum
APDV 35	0313896	35	Aluminum
APDV 85	0313416	55	Aluminum
APEH 35	0313893	35	Aluminum
APEH 85	0313413	55	Aluminum
APEV 35	0313895	35	Aluminum
APEV 85	0313415	55	Aluminum

ZZA intermediate stop on the piston side

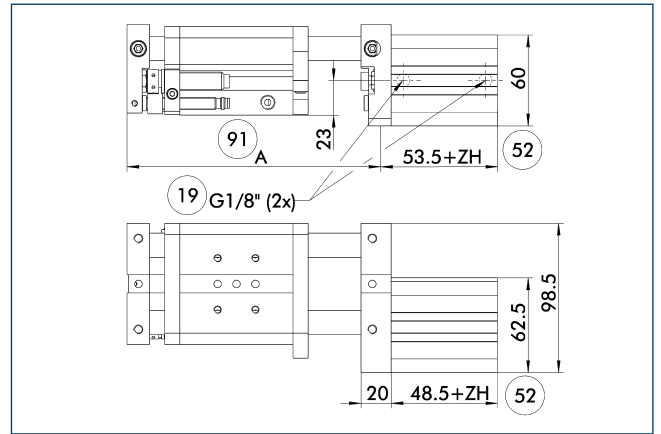

- ①⑨ Air connection
- ⑤② Intermediate stroke
- ⑨① Overall length "A", the variant without intermediate stroke (see measurement chart of stroke variants)

The intermediate position is measured from the respective end position. The intermediate position can be approached from both sides and can proceed in the original stroke direction. The holding force is the piston force of the intermediate stop less the piston force of the linear module.

Description	Holding force [N]	With with 0 mm stroke [kg]	Weight per mm stroke [kg]
Intermediate stop			
ZZA105	460	0.75	0.006

- ④ Sample order KLM 100-H100-ZZA105-H30

ZZA intermediate stop on the piston rod side

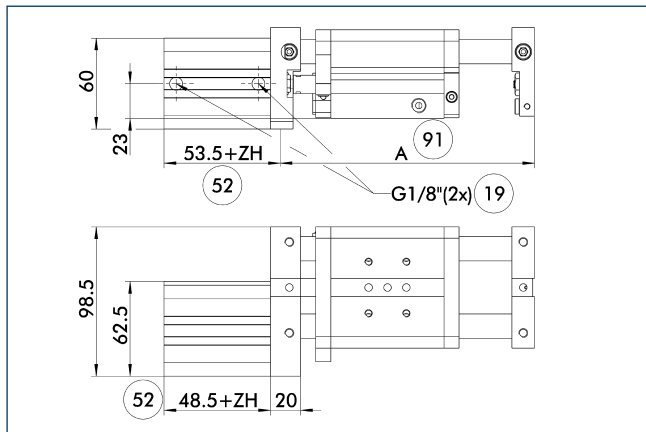

- ①⑨ Air connection
- ⑤② Intermediate stroke
- ①⑨ Overall length "A", the variant without intermediate stroke (see measurement chart of stroke variants)

The intermediate position is measured from the respective end position. The intermediate position can be approached from both sides and can proceed in the original stroke direction. The holding force is the piston force of the intermediate stop less the piston force of the linear module.

Description	Holding force	With with 0 mm stroke	Weight per mm stroke
	[N]	[kg]	[kg]
Intermediate stop			
ZZA 106	460	0.75	0.006

① Sample order KLM 100-H100-ZZA106-H30

Design – variant 1

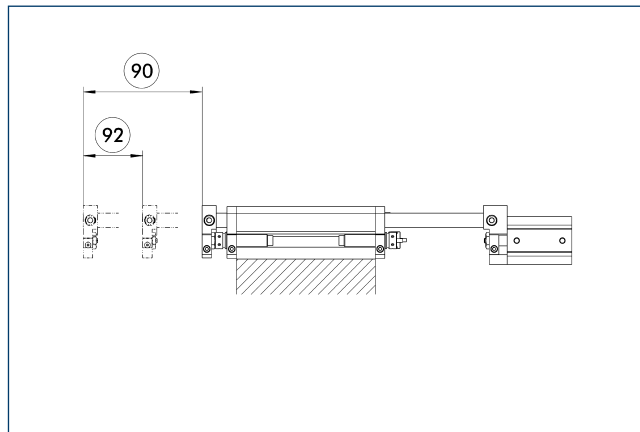

- ⑨① Nominal stroke
- ⑨② Intermediate stroke

The corresponding intermediate stroke (ZH) is calculated by subtracting the intermediate stop cylinder stroke from the nominal stroke of the module. The intermediate stroke adjustment is ±3 mm.

Design – variant 2

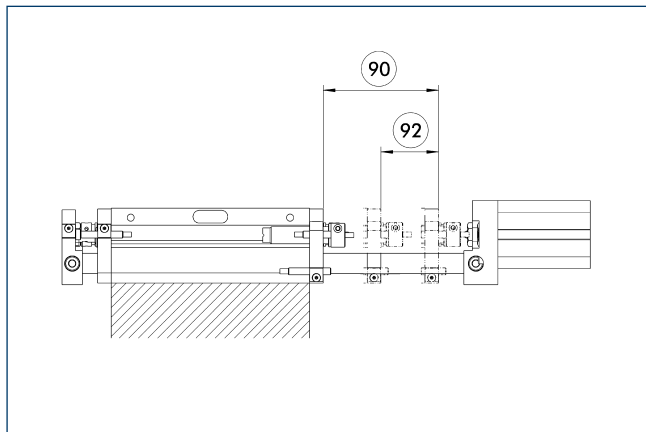

- ⑨① Nominal stroke
- ⑨② Intermediate stroke

The corresponding intermediate stroke (ZH) is calculated by subtracting the intermediate stop cylinder stroke from the nominal stroke of the module. The intermediate stroke adjustment is ±3 mm.

Modular assembly automation

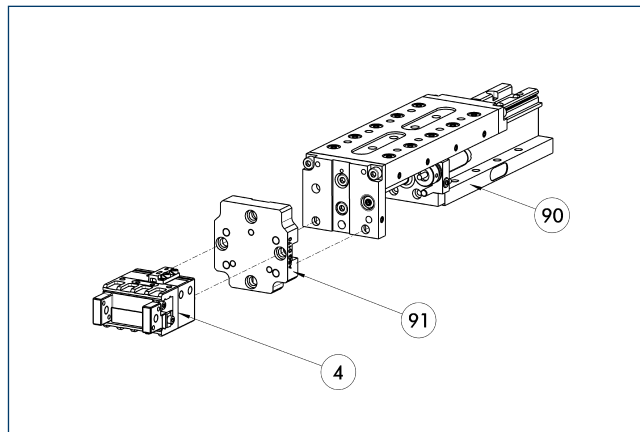

- ④ Grippers
- ⑨① CLM/KLM/LM/ELM/ELS/HLM linear modules
- ⑨① ASG adapter plate

Grippers and linear modules can be combined with the standard modular system for modular assembly automation. For more information see our main catalog "Modular Assembly Automation".

Inductive proximity switches

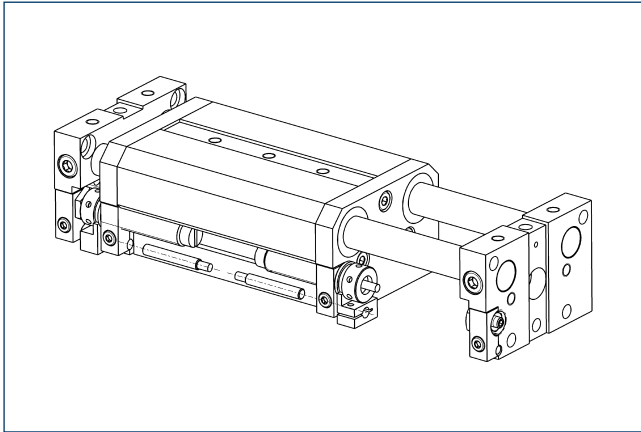

Directly mounted end position monitoring.

Description	ID	Often combined
Inductive proximity switches		
NI 30-KT	0313429	
Cable extension		
KV BW08-SG08 3P-0030-PNP	0301495	
KV BW08-SG08 3P-0100-PNP	0301496	
KV BW08-SG08 3P-0200-PNP	0301497	●
Connection cables		
KA BG08-L 3P-0300-PNP	0301622	●
KA BG08-L 3P-0500-PNP	0301623	
KA BW08-L 3P-0300-PNP	0301594	
KA BW08-L 3P-0500-PNP	0301502	

- ① Two sensors (closer/S) are required for each unit and extension cables are available as an option. For sensor cables, note the minimum permissible bending radii. These are generally 35 mm.

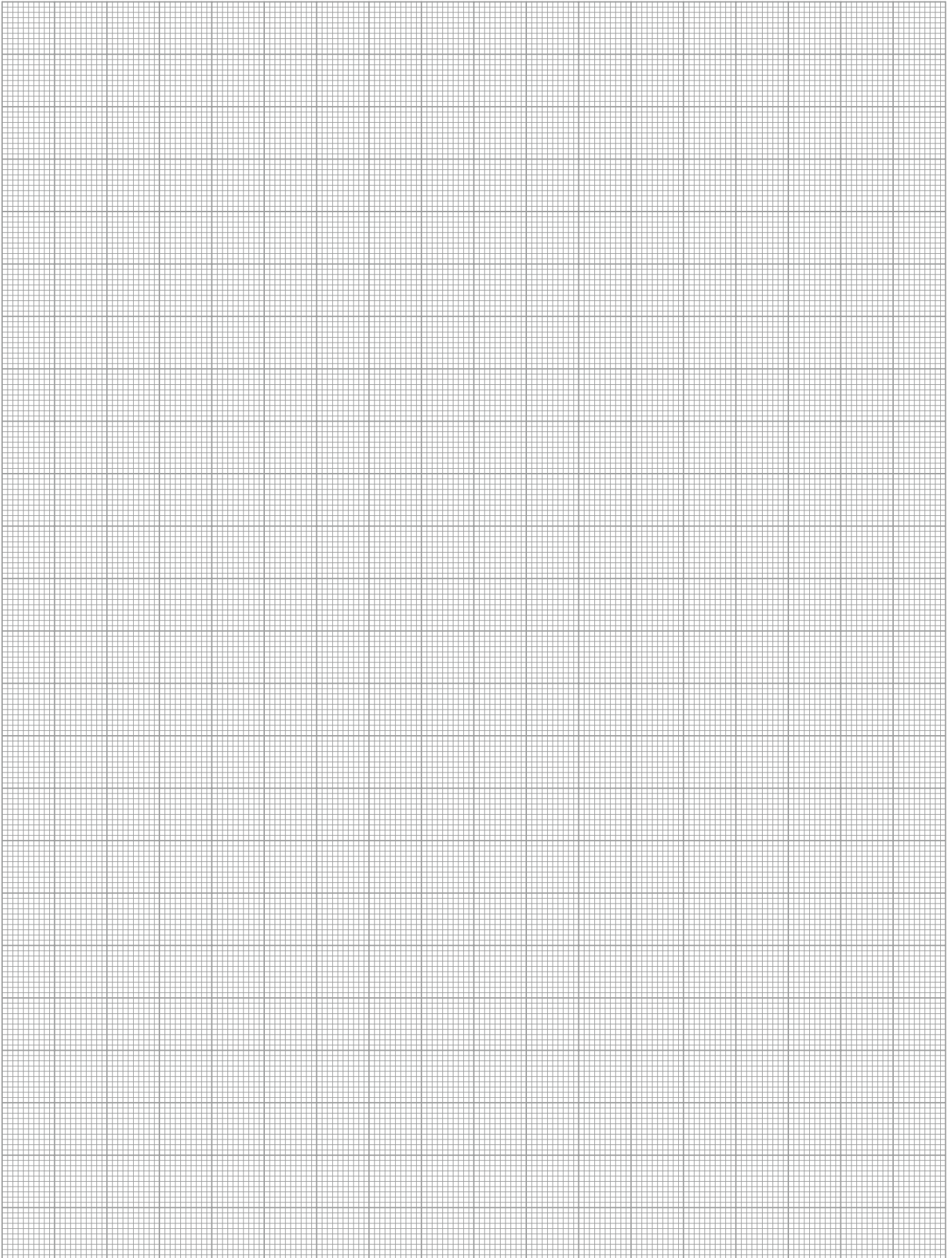

Forces and moments

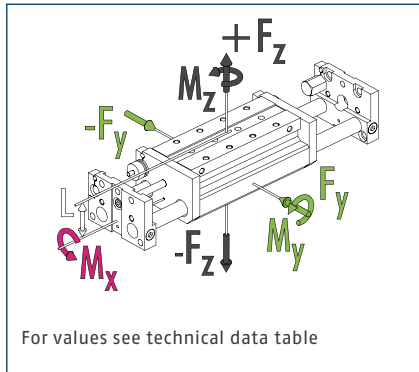

ⓘ The forces and moments shown here are maximum values for individual loading. If more than one force and/or moment occurs simultaneously, the case of application can be calculated by the TOOLBOX. The force F_y can just be calculated by the TOOLBOX.

Technical data

Description		KLM 300-H050	KLM 300-H100	KLM 300-H150	KLM 300-H200	KLM 300-H250	KLM 300-H300
ID		0314550	0314554	0314558	0314562	0314566	0314570
Stroke	[mm]	50	100	150	200	250	300
Extend force	[N]	753	753	753	753	753	753
Retracted force	[N]	633	633	633	633	633	633
Repeat accuracy	[mm]	0.03	0.03	0.03	0.03	0.03	0.03
Piston diameter	[mm]	40	40	40	40	40	40
Bar diameter	[mm]	16	16	16	16	16	16
Min./max. operating pressure	[bar]	3/8	3/8	3/8	3/8	3/8	3/8
Nominal operating pressure	[bar]	6	6	6	6	6	6
Fluid consumption/10 mm stroke	[cm ³]	12.57	12.57	12.57	12.57	12.57	12.57
Overall length	[mm]	324	324	524	524	724	724
Protection class IP		40	40	40	40	40	40
Min./max. ambient temperature	[°C]	5/60	5/60	5/60	5/60	5/60	5/60
Weight	[kg]	6.9	6.8	9.8	9.7	12.7	12.6
Drive concept		Piston rod cylinders	Piston rod cylinders	Piston rod cylinders	Piston rod cylinders	Piston rod cylinders	Piston rod cylinders
Length L	[mm]	61	61	61	61	61	61
Moments M_x max./ M_y max./ M_z max.	[Nm]	90/200/200	90/200/200	72/350/350	72/350/350	54/415/415	54/415/415
Forces F_z max.	[N]	3120	3120	2490	2490	1870	1870
Options and their characteristics							
Dust-tight version		KLM 300-H050-SD	KLM 300-H100-SD	KLM 300-H150-SD	KLM 300-H200-SD	KLM 300-H250-SD	KLM 300-H300-SD
ID		0314552	0314556	0314560	0314564	0314568	0314572
Protection class IP		50	50	50	50	50	50
Rod lock version		KLM 300-H050-ASP	KLM 300-H100-ASP	KLM 300-H150-ASP	KLM 300-H200-ASP	KLM 300-H250-ASP	KLM 300-H300-ASP
ID		0314551	0314555	0314559	0314563	0314567	0314571
Stroke loss of nominal stroke (on the rod side)	[mm]	22	22	22	22	22	22
Weight	[kg]	7.4	7.3	10.3	10.2	13.2	13.1
Static holding force	[N]	1000	1000	1000	1000	1000	1000
Max. axial backlash of the clamping	[mm]	0.25	0.25	0.25	0.25	0.25	0.25
Min. release air pressure	[bar]	3	3	3	3	3	3

Main view

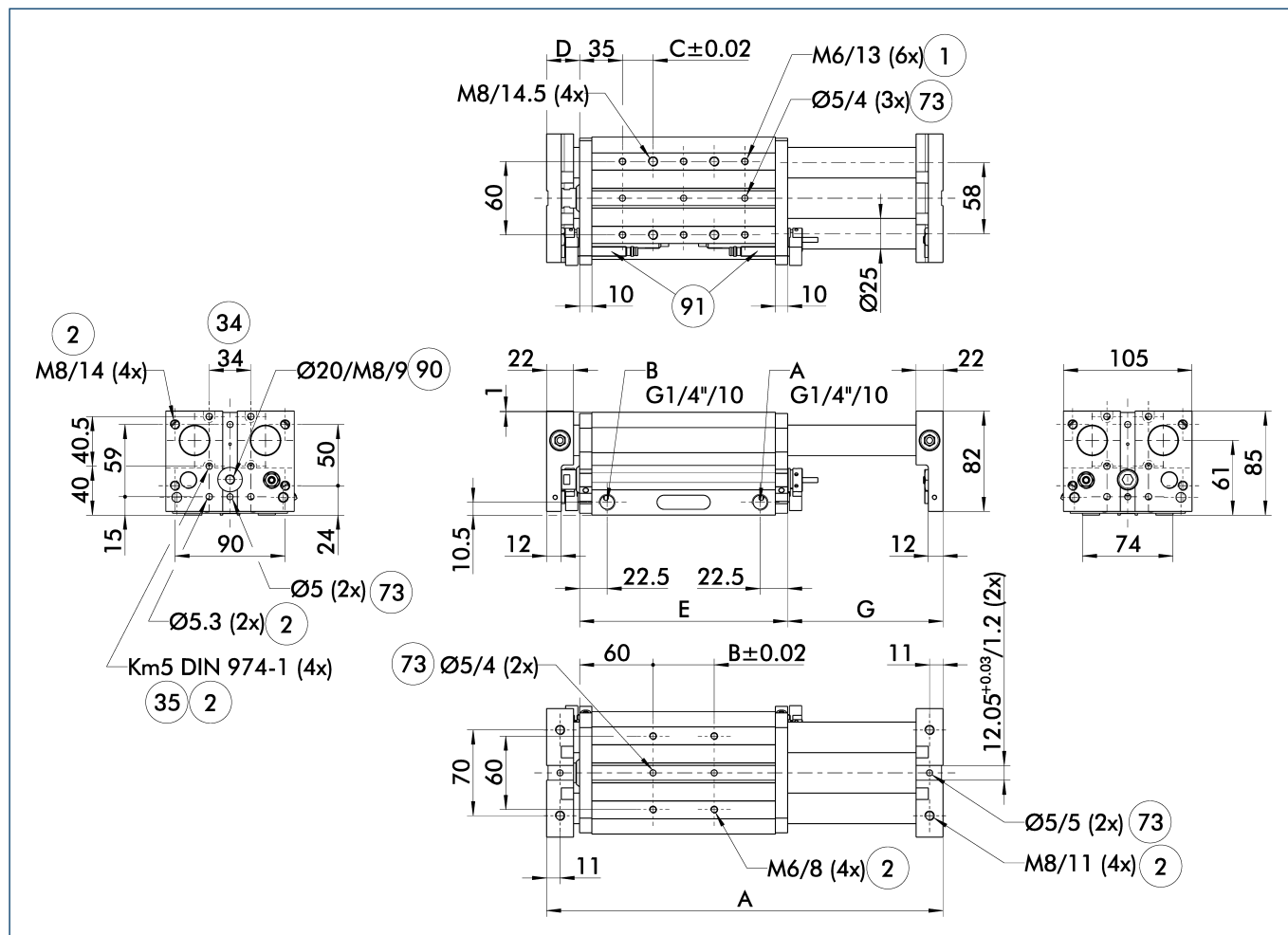

The linear module can be fastened either to the base body or the face plates. The structure can also optionally be fastened to either the face plates or the base body. This view shows the mounting of the module to the base body and the mounting of the structure to the face plates.

- A Main connection - linear unit extended
- B Main connection - linear unit retracted
- ① Connection linear unit
- ② Attachment connection
- ③④ On both sides
- ③⑤ Back side
- ⑦③ Fit for centering pins
- ⑨⑩ Through-holes in the face plate and thread in the base body (only single sided)
- ⑨① Inductive proximity switches

Description	A	B	Quantity B	C	Quantity C	D	E	G
	[mm]	[mm]		[mm]		[mm]	[mm]	[mm]
KLM 300-H050	324	50	1	25	4	27	170	127
KLM 300-H100	324	50	1	25	4	27	170	127
KLM 300-H150	524	50	3	25	8	27	270	227
KLM 300-H200	524	50	3	25	8	27	270	227
KLM 300-H250	724	50	5	25	12	27	370	327
KLM 300-H300	724	50	5	25	12	27	370	327

SD dust-tight version

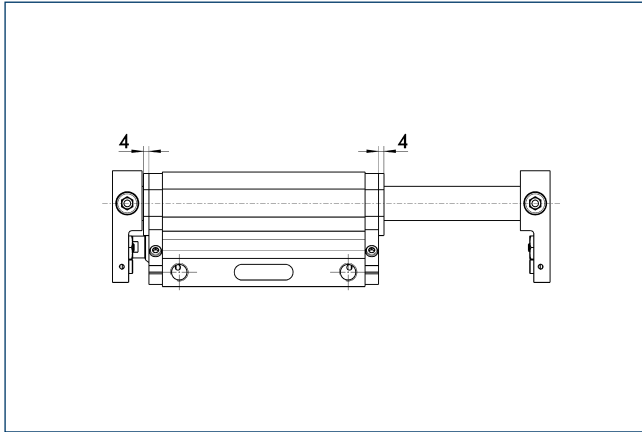

The dust cover option increases the protection against external particles.

Fine adjustment

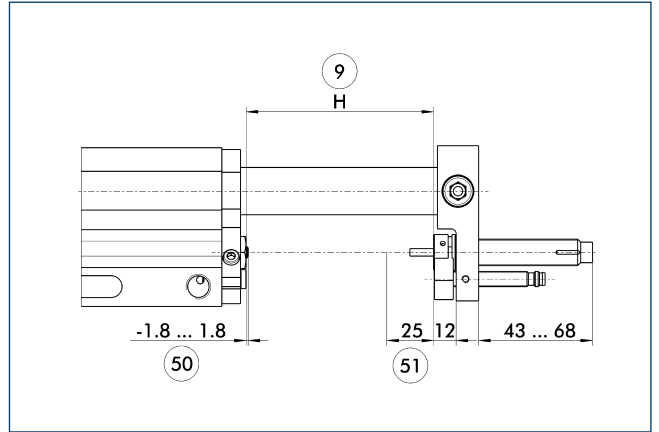

- ⑨ Effective stroke
- ⑤① Stroke adjustment range
- ⑤① Damping stroke adjustment range

Shock absorbers can be mounted either on the base body or on the face plates. This illustration shows the mounting on the face plates and the possibility of stroke fine adjustment.

Fine adjustment

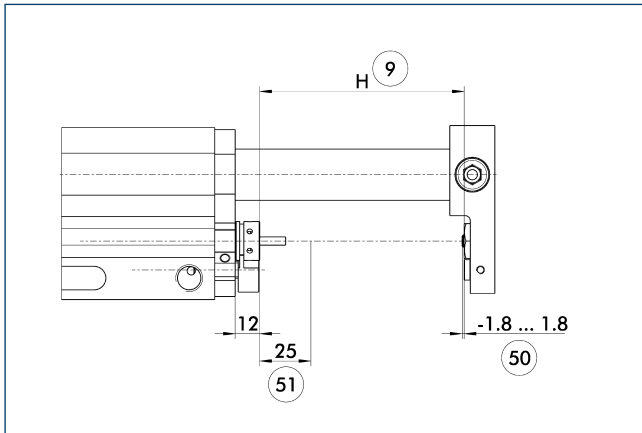

- ⑨ Effective stroke
- ⑤① Stroke adjustment range
- ⑤① Damping stroke adjustment range

Shock absorbers can be mounted either on the base body or on the face plates. This illustration shows the mounting on the base body and the possibility of stroke fine adjustment.

Rod lock

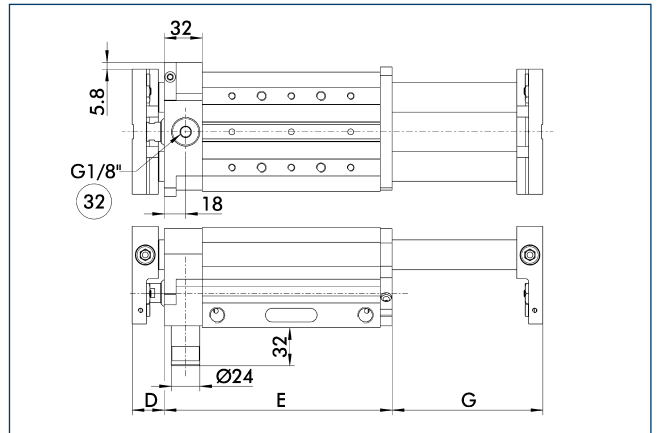

- ③② Pneumatic connection for holding brake

The rod lock prevents weights from falling in the event of energy loss, such as emergency stop situations. The rod lock can also be retrofitted, but this will reduce the effective stroke.

Description	D [mm]	E [mm]	G [mm]
KLM 300-H050-ASP	27	192	105
KLM 300-H100-ASP	27	192	105
KLM 300-H150-ASP	27	292	205
KLM 300-H200-ASP	27	292	205
KLM 300-H250-ASP	27	392	305
KLM 300-H300-ASP	27	392	305

Attachment to a pillar assembly system

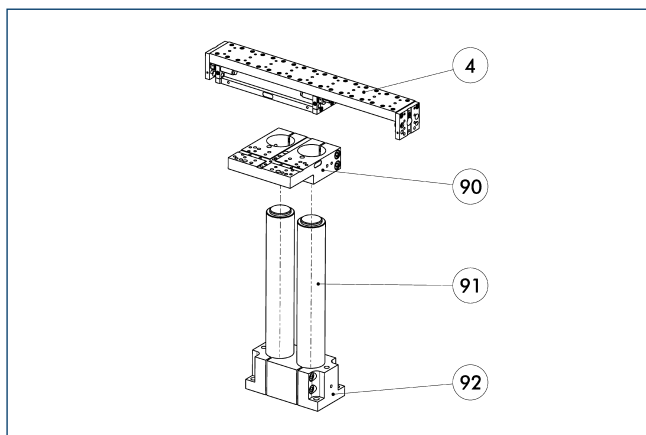

- ④ Linear unit
- ⑨① Pillars, hard-chromium plated, ground
- ⑨② SOD double socket
- ⑨② APDH double mounting plate

This unit can be attached to the pillar assembly system as standard. See the SCHUNK Kombibox software, which can be found online, for the right arrangement for your application.

Description	ID	Pillar diameter [mm]	Material
Pillar assembly system mounting plates			
APDH 85	0313414	55	Aluminum
APDV 85	0313416	55	Aluminum
APEH 85	0313413	55	Aluminum
APEV 85	0313415	55	Aluminum

ZZA intermediate stop on the piston side

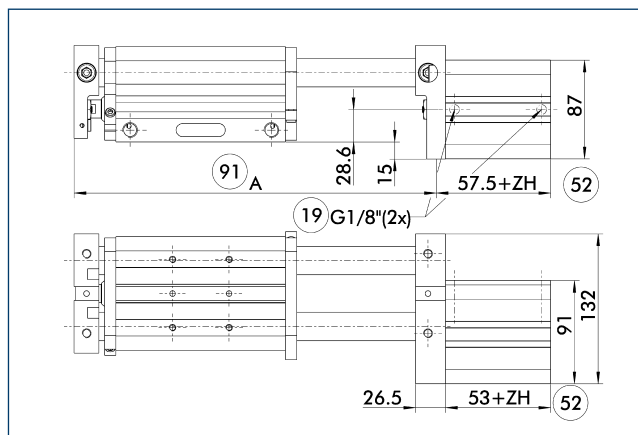

- ⑨① Overall length "A", the variant without intermediate stroke (see measurement chart of stroke variants)
- ⑨② Intermediate stroke
- ⑨② Air connection

The intermediate position is measured from the respective end position. The intermediate position can be approached from both sides and can proceed in the original stroke direction. The holding force is the piston force of the intermediate stop less the piston force of the linear module.

Description	Holding force [N]	With with 0 mm stroke [kg]	Weight per mm stroke [kg]
Intermediate stop			
ZZA 305	1117	2.1	0.011

ZZA intermediate stop on the piston rod side

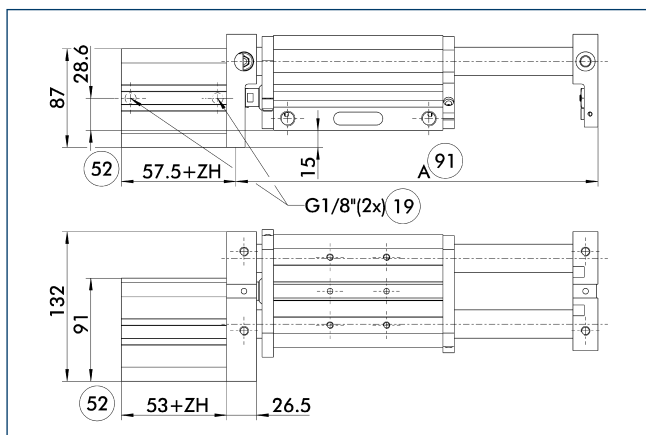

- ⑨① Overall length "A", the variant without intermediate stroke (see measurement chart of stroke variants)
- ⑨② Intermediate stroke
- ⑨② Air connection

The intermediate position is measured from the respective end position. The intermediate position can be approached from both sides and can proceed in the original stroke direction. The holding force is the piston force of the intermediate stop less the piston force of the linear module.

Description	Holding force [N]	With with 0 mm stroke [kg]	Weight per mm stroke [kg]
Intermediate stop			
ZZA 306	1117	2.1	0.011

① Sample order KLM 300-H100-ZZA306-H100

Design – variant 1

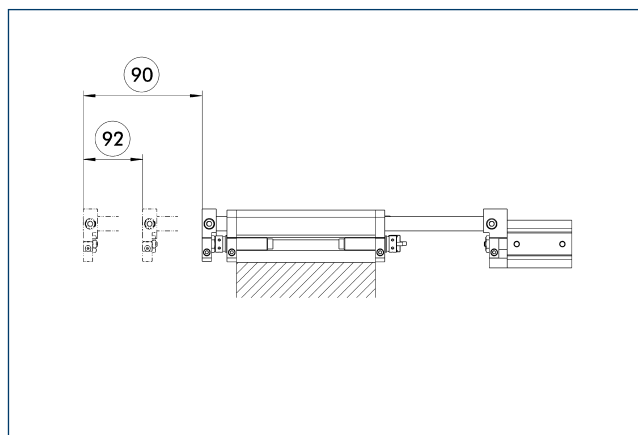

- ⑨② Intermediate stroke
- ⑨② Nominal stroke

The corresponding intermediate stroke (ZH) is calculated by subtracting the intermediate stop cylinder stroke from the nominal stroke of the module. The intermediate stroke adjustment is ±3 mm.

KLM 300

Pneumatic Components | Linear Module

Design – variant 2

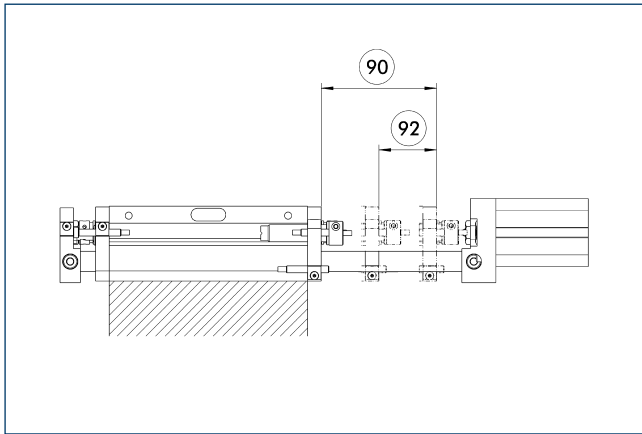

90 Nominal stroke

92 Intermediate stroke

The corresponding intermediate stroke (ZH) is calculated by subtracting the intermediate stop cylinder stroke from the nominal stroke of the module. The intermediate stroke adjustment is ± 3 mm.

Modular assembly automation

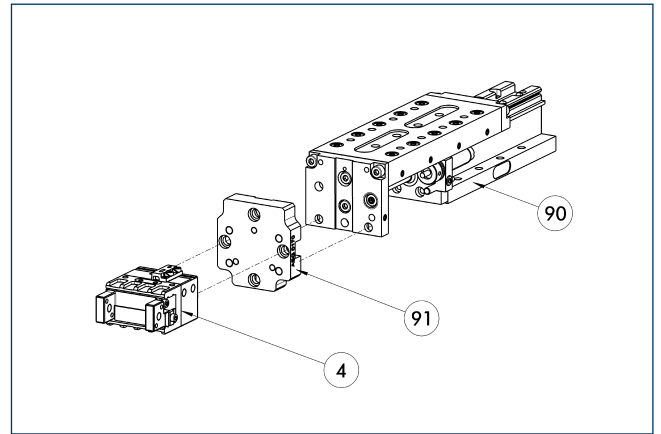

4 Grippers

91 ASG adapter plate

90 CLM/KLM/LM/ELP/ELM/ELS/HLM linear modules

Grippers and linear modules can be combined with the standard modular system for modular assembly automation. For more information see our main catalog "Modular Assembly Automation".

Inductive proximity switches

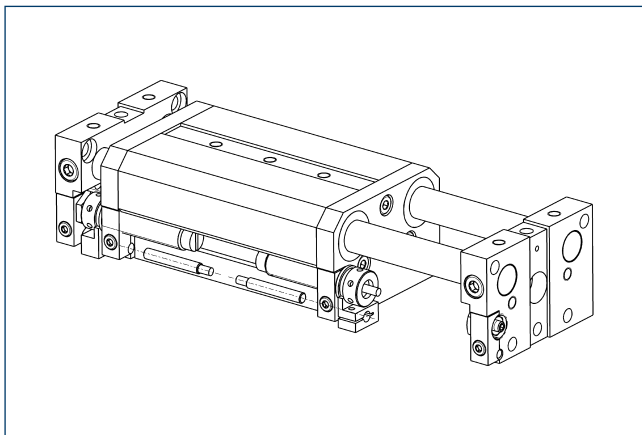

Directly mounted end position monitoring.

Description	ID	Often combined
Inductive proximity switches		
NI 30-KT	0313429	
Cable extension		
KV BW08-SG08 3P-0030-PNP	0301495	
KV BW08-SG08 3P-0100-PNP	0301496	
KV BW08-SG08 3P-0200-PNP	0301497	●
Connection cables		
KA BG08-L 3P-0300-PNP	0301622	●
KA BG08-L 3P-0500-PNP	0301623	
KA BW08-L 3P-0300-PNP	0301594	
KA BW08-L 3P-0500-PNP	0301502	

① Two sensors (closer/S) are required for each unit and extension cables are available as an option. For sensor cables, note the minimum permissible bending radii. These are generally 35 mm.